

Table of contents

Application Area and Purpose	3
1 General information	4
1.1 Scope of supply	4
1.2 Sustainability	4
1.3 Systems supporting design	5
2 File designation and name formatting	6
2.1 File designations	6
2.2 Allocation of drawing numbers/product structure	7
3 File structure	8
3.1 Project phase	8
3.2 Manufacturing phase	8
4 Changes in projects	8
5 Definition of terms	9
6 Handling bought-in parts	10
7 Labeling, servicing, and maintenance	11
8 Welded structures	12
8.1 Presentation of the processing states	12
9 Producing drawings	13
9.1 Labeling for main assemblies and assemblies	13
9.1.1 <i>Assemblies</i>	13
9.1.2 <i>Main assemblies</i>	13
9.1.3 <i>Layout</i>	13
9.2 General information (drawing labels)	15
9.2.1 <i>Position numbers</i>	15
9.2.2 <i>Electrical components</i>	16
9.2.3 <i>Welded assemblies</i>	16
9.2.4 <i>Lubrication points</i>	16
9.2.5 <i>Presentation of the pin holes in the drawings</i>	17
9.3 General information (process in CAD)	19
9.4 Dimensioning	19
9.5 Test dimensions	21
9.6 Engraving	23
9.7 Weight	23
9.8 Drawings of welded parts	23
9.9 Title block	24
9.10 Drill hole tables	27
10 Data transmission	27

Change history:

27	Section 1.2 added	changed	Kropf	05/06/2026
26	Point 5 supplemented	changed	Kropf	07/08/2025
25	Omitted Sheet size	changed	Kropf	05/16/2023
24	Add point 1.2 sustainability	changed	Kropf	04/19/2023
23	Replace AMS with SAP	changed	Kropf	02/02/2022
22	9.2.6. entfällt / 9.2.4 geändert	changed	Kropf	08/01/2019
21	Change of company logo; 9.8 changed	changed	Kropf	11/28/2018
20	Points 5 and 6 of section 8.1 have been removed	changed	Kropf	11/14/2016
19	BN 10.012 on page 3; 9.2.5 Description of pin holes, removed	changed	Kropf	9/19/2016
18	9.5 Labeling with test dimensions	changed	Kropf	2/10/2016
17	2.1, 9.2 pos. no., three-digit	Correction	Kropf	2/23/2015
16	Approval module revised	changed	Otholt, S.	11/18/2014
15	Information text added for release	Changed	Otholt, S.	10/8/2014
14	9.2.5 Formatting, 9.8 reference to BN10.050 9.4.16+17 addition	changed	Kropf	9/30/2014
13	Application area, 1, 3, 4, 6, 9.4, 9.5, 9.9	changed	Kropf	9/3/2014
12	Change of company logo	Changed	Baumann	8/9/2012
11	Point 6 amended	changed	Wilken	7/5/2012
10	Point 8 8, 8.9 modified, 8.11, 8.12 removed	changed	Hartmann	11/25/2011
09	Point 7.1.5-7 / 8.10-12 added, 9.2 removed / 7.1.2 + 8.2 supplemented	changed	Kropf	9/28/2011
08	Point 9.4 / 6 not applicable	changed	Völz	4/26/2011
07	Point 9.4 / 9.5 / 9.9	changed	Kropf/Mch	2/16/2011
06	Point 9.4	changed	Kropf	9/29/2010
05	Point 5 addition / 10.9	changed	Nol / Mch	1/28/2010
04	Point 10.3	changed	Nolting	10/29/2009
03	Point 7.4 / 10.6	changed	Nolting	10/5/2009
02	Point 2.2 / 4.1 / 6 / 10.5 / 10.6	changed	Nolting	9/24/2009
01	Point 10.4 / 10.7	changed	Strozyk	7/13/2009
00	Design Specification	Approved	Nolting	5/18/2009
Index	Description	Status	Name	Date

Released:

The authoritative and approved version of this company standard is only available on the Broetje Automation intranet. Hard copies and locally stored copies must be verified as they are not subject to change management. The website of Broetje Automation "www.broetje-automation.de" serves as an alternative source of company standards for external parties.

Application Area and Purpose

This specification describes the methods and specifications for producing design documents. It is binding for all members of staff within the design department at Broetje-Automation GmbH and for contractors who undertake design work for these companies. The factory standard 10.030 CATIA Specification has to be implemented in addition to this specification.

The implementation specification design is constantly being extended and refined. How far these extensions are binding for current projects is linked to the necessary expenditure (costs and completion date) and has to be decided in the specific case by the managing designer.

Sample files are enclosed to explain the implementation specification design:

- BN70-050 External Office Part List Template
- BN10-050 Welding Instruction Design

External offices can request these documents from Broetje Automation or view them on FTP.

1 General information

1.1 Scope of supply

- 1) The scope of supply for design services always includes the design (3D), the creation of drawings (2D) geometry, and the associated part lists.
- 2) The data is generated on the CATIA V5 system. The process for this can be found in the CATIA V5 factory standard. Data that does not correspond to the specification is rejected.

Further or amended requirements are possible for a specific project and are defined in the technical or commercial requirement.

1.2 Sustainability

- 1) Minimum material consumption - wall thicknesses are designed to be as thin as possible and as thick as necessary and, if necessary, checked by FEM calculation - see also BN10.050 chap. 2.5.1 - SWT instruction
- 2) Material selection - see BN20.010 - Material selection list
- 3) Construction with easy assembly / disassembly - see also QG22
- 4) 3D printed components - low stressed small parts are preferably produced by FDM (Fused Deposition Modelling) process, choosing here materials of organic origin and with good recycling possibilities - see BN20.010 - Material selection list.
- 5) MRP Code - To ensure sustainable component selection, the MRP code in the CDB is regularly synchronized with SAP. This allows the design team to see at a glance whether, for example, a standard part is a bulk item (MRP code "ND"). This prevents the purchase of large quantities that would otherwise have to be disposed of, as standard parts are generally not stocked due to their low value. At the same time, standard greases, for example, have also been reclassified as "bulk goods," as they are now ordered only as needed and leftovers do not have to be disposed of.
- 6) Preferred lists – Using preferred lists in the design phase conserves resources, reduces the variety of parts and inventory requirements, and increases procurement efficiency. Machine downtime is resolved more quickly because the required parts are standardized and available on short notice.

1.3 Systems supporting design

The SAP system is the basis of effective design. (ERP)

Information about the process flow at BA or documents supporting the process can be found on the BA intranet under "BADM":

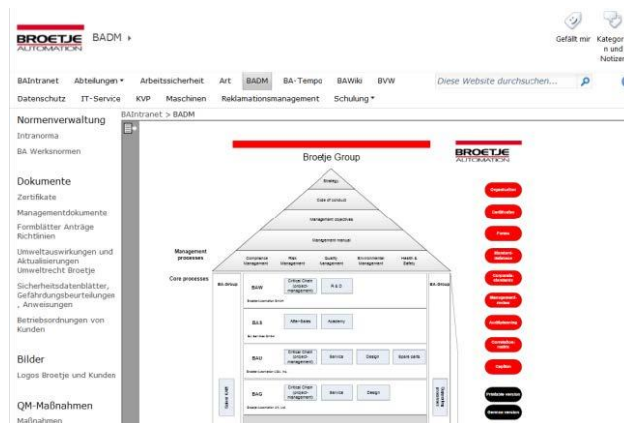

CATIA V5 data has been administered since August 1, 2009 with the help BA-PDM:

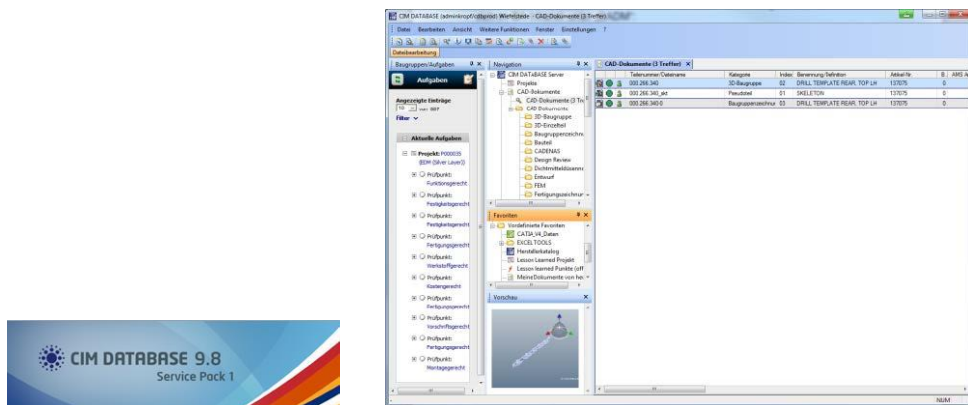

External members of staff receive instruction about these systems before the start of design, and the necessary information is provided by the project manager.

Standard part ISOXXXX_XXXXX

Example:

iso4762_m6x15

Bought-in part Company_Order relationship_Name of manufacturer

Example:

norelem_xyz_bracket

Riveting N_XXXXXX_X-X

Example:

n_bacr15ft_8-6

2.2 Allocation of drawing numbers/product structure

- 1) Drawing numbers are assigned on the PDM system when a project is planned in advance.
There is a structure list with the corresponding assemblies and drawing numbers for each project. This structure list is binding for all members of staff and external offices.

Extract from a Part List:

F	1000.000	Aufstellplan	810003	900.223.402	0	1,00	ST	28.06.200	30.06.2004	
G	2000.000	Positionierer	808451	100.220.500	0	1,00	ST	29.03.200	29.03.2004	
G	2010.000	Schiensystem X1,kompl	808452	035.220.502	0	1,00	ST	05.03.200	29.03.2004	
G	2010.001	Schiensystem X1	809143	030.220.503	0	1,00	ST	30.07.200	30.07.2004	N
F	2015.001	Umsetzwagen - Oberwagen	818949	030.223.468	0	1,00	ST	15.10.200	15.10.2004	
F	2015.002	Umsetzwagen - Unterwagen	818497	030.223.469	0	1,00	ST	15.10.200	15.10.2004	
F	2015.003	Schiensystem Z2	818752	010.223.470	0	1,00	ST	30.09.200	22.10.2004	

- 2) Broetje Automation sets the product structure of a project (at least in extracts).



Changes to this structure always have to be agreed with the managing designer. Any changes made independently may result in the file being rejected.

3 File structure

3.1 Project phase

All CAD data can be saved in BA-PDM. External offices save all references in a directory (including bought-in and standard parts).

3.2 Manufacturing phase

Approved drawings are saved as PDFs on N:/Zeichnungen. These PDFs are produced automatically in BA-PDM for CATIA V5 drawings and saved there.

For other CAD systems (e.g.: SolidWorks), the author/editor of the drawing has to produce a PDF and save it there.

4 Changes in projects

All changes to approved drawings are documented. Documentation must take place in BA-PDM that is brought automatically from there to the CATIA V5 drawings. The entries must be made by hand for all drawings that are not CATIA V5.

External offices have to provide a change description in the form of an Excel spreadsheet including the change text.

5 Definition of terms

Bought-in parts

All parts to which no further work is required are considered to be bought-in parts. (Examples: engine, gears, gear wheels, ball screw spindles etc.) These are given an ERP mat. no. and the CAD category “purchased part”.

Purchase part as per drawing

Receives a mat. no. in the ERP and is treated as a purchased part. In CAD it is assigned the category Broetje.

Production Parts and Bought-in Parts with Subsequent Work

All parts that are processed or are reworked (burnishing, hardening, drilling etc.) are considered as production parts or bought-in parts with subsequent work and therefore cannot be used directly in the condition in which they are supplied. Such parts are also given a drawing number (with or without format) as file names and the CAD category “Broetje”. (Examples: Standard parts such as burnished washers, DU bushing with subsequent work)

Standard parts

Screws, splints, disks, pins, bolts and nuts etc. are considered to be standard parts.

6 Handling bought-in parts

Bought-in parts are named as follows:

Manufacturer_Type Designation_Designation

Example: alpha_pkf300_xx_angular gear

The designation should be removed from the manufacturer's catalog.
The name is consistently written in lower case (excluding file extension)

Example: alpha_pkf300_xx_angular gear.CATPart

Care should be taken that only the preferred bought-in parts are used. In general, the following must be determined:

1. As few bought-in parts as possible should be created
2. Only bought-in parts that have already been created may be used
3. Only bought-in parts from approved suppliers have to be used
4. There must be an absolute necessity for exceptions – bought-in parts for suppliers who have not been approved.



Handling standard and bought-in parts that are saved in BA-PDM takes place in accordance with the “CAD Handout – Generating Bought-in Parts

7 Labeling, servicing, and maintenance

All individual parts and assemblies have to be identified with respect to the required servicing and maintenance. This is undertaken in AMS by service internal sales in the FDR phase.

All instructions, such as:

- Function
- Tight fit
- Tightness
- Etc.

should be related globally to the assemblies.

Only special instructions should be labeled for individual parts, such as

- Replacing filter cartridges
- Cable damage
- Reference manufacturing documentation

Screws and pins are generally not labeled.

To identify the necessary work, the required qualifications for service personnel (mechanics, electricians etc.) and the time required must be entered.

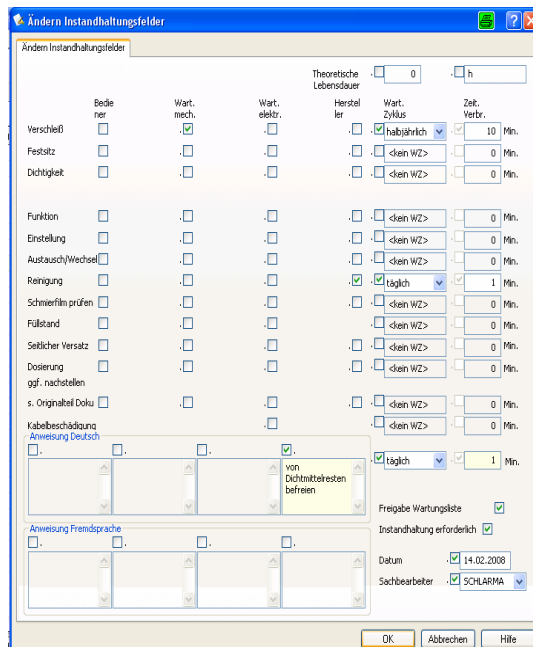

8 Welded structures

8.1 Presentation of the processing states

- 1) For manufacturing drawings for welded structures, the individual processing steps must be spread over several drawing pages. See also sample drawings.

Sequence: Page1 = machining
 Page2 = weld set dimensions, weld symbols
 Page3 = trims, thermally-cut parts, unfinished parts, blanks

- 2) The items and dimensions of the individual welded parts also have to be measured when the measuring the machining (Page1). The zero point rivet has to be reasonably set for machining.
- 3) It may also make sense in the particular case for individual processing step to be spread over several pages. In cases of doubt, a decision always has to be made in favor of clarity and readability of the drawings.
- 4) Flame-cut parts of individual parts of a welded structure are manufactured using DXF files. In this case, it is sufficient, only to enter the external dimensions and generate a corresponding entry using the title block (= *manufactured in accordance with DXF files*).
- 5) Page 2 of the welded drawing part is not required for welded parts that cannot be represented on the drawing. In this case, the welded information must be placed on Page 1.

Related documents are:

- BN10.050 Welding Instruction Design
- CAD Handout – Development of Welded Assemblies

9 Producing drawings

9.1 Labeling for main assemblies and assemblies

9.1.1 Assemblies

Assemblies only include workpieces.

9.1.2 Main assemblies

Main assemblies only include further assemblies (=subassemblies).

No assemblies or individual parts are added in main assemblies but only the subassemblies listed in the structure list (AMS).

A 2D drawing for each main assembly must exist for each main assembly within the AMS assembly structure.

9.1.3 Layout

Main assemblies are to be applied in the layout (XXXX.000).

There is a drawing for each main assembly (XXX.000). The associated subassemblies have to be represented and applied in these drawings (assembly number from AMS). If a subassembly is fitted more than once within a main assembly, this also has to be applied several times.

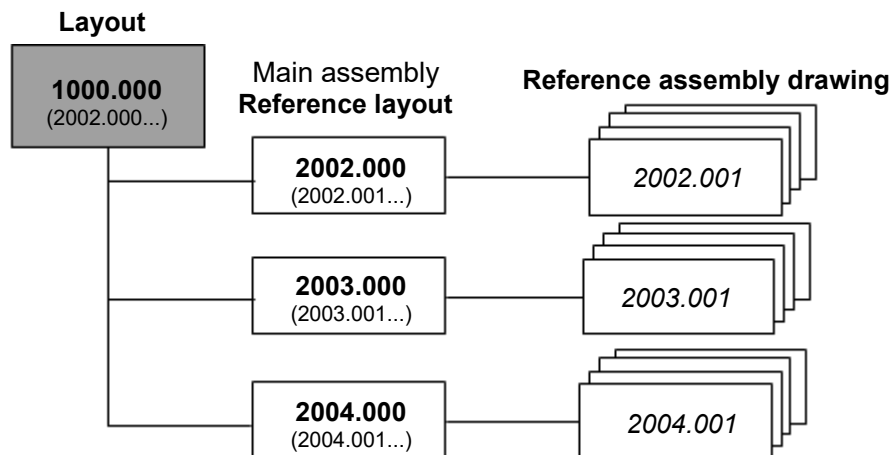

A distinction is made here between assembly number (XXXX.000) and drawing number (XXX.XXX.XXX). The assembly number represents a classification and the drawing number serves as identification. Assembly numbers and drawing numbers are assigned by Broetje (structural overview from AMS).

Example of a layout with details of the main assemblies:

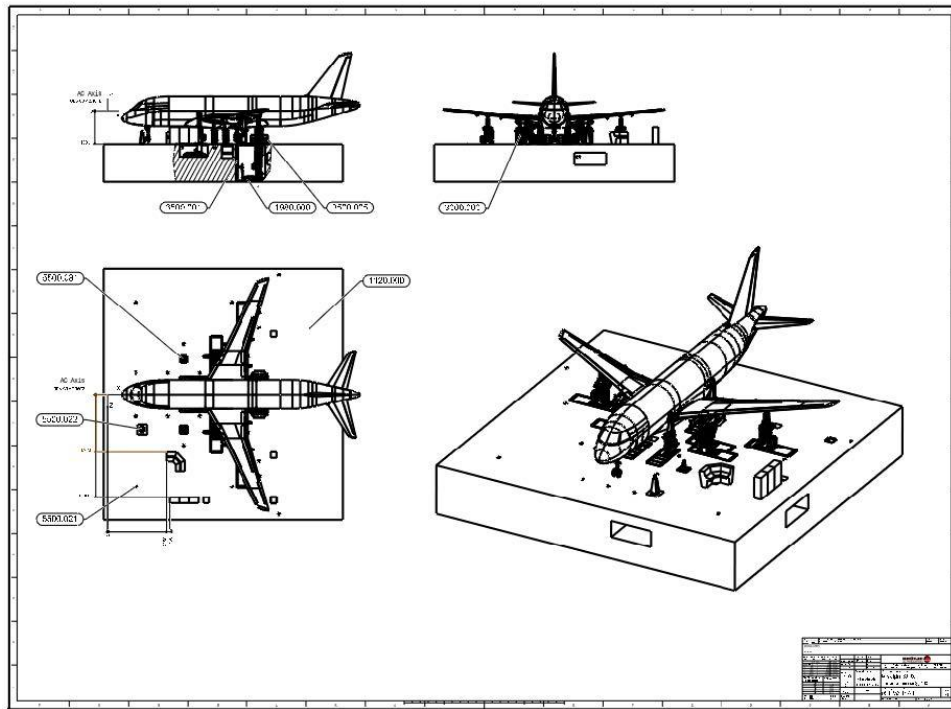

Identification of the main assemblies:

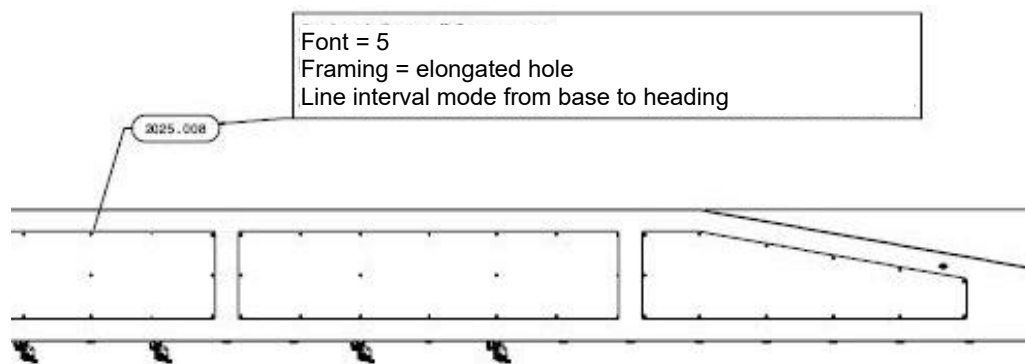

All assembly drawings have to be given system dimensions. It must be possible to take the maximum dimensions of an assembly and important information, such as strokes, from these. The weight of the assembly must be entered above the title block. See here also sample drawings.

How far the representation of details (installation, switch boxes, connections etc.) vary from the assembly drawing should be discussed with the supporting designer. This applies equally to special entries, such as tightening torque for screw connections, creating assembly drawings etc.

9.2 General information (drawing labels)

9.2.1 Position numbers

A distinction is made using the number range of items whether it is a bought-in part, production part (bought-in part with subsequent work), or standard part. (001-099, 101-199, 201-299). A distinction is also made between production parts and bought-in parts with subsequent work by means of a horizontally separated reference range.

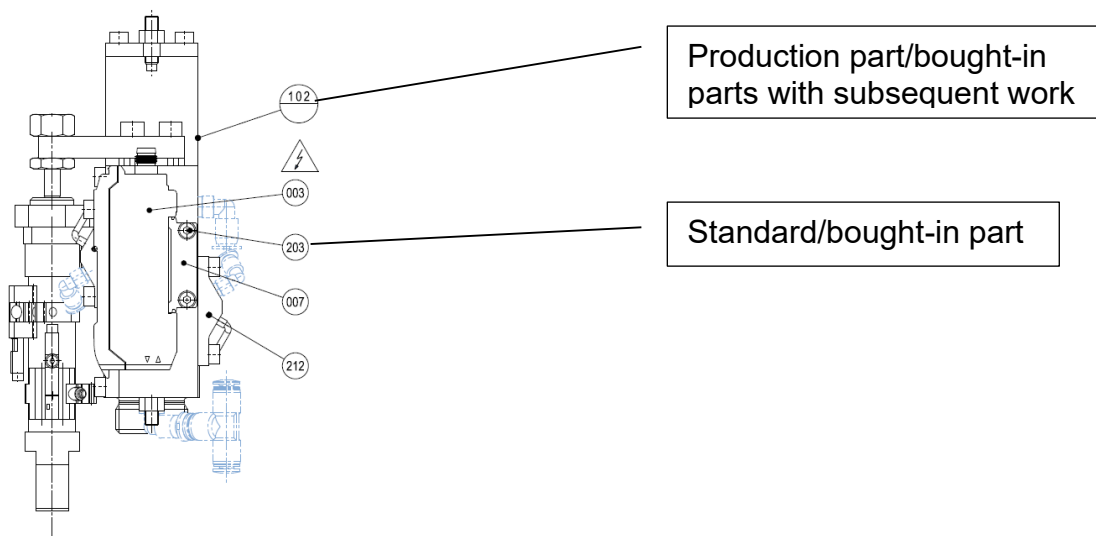

Care should be taken with the consistency of the presentation (same size), and to apply all workpieces in the assembly drawing.

Screws and similar standard parts that fasten a production or bought-in part or are fitted into this can be identified together with this part by using their position number (consecutive position ranges)

Torques for screws that differ from the usual table values are detailed on the drawing.

The tightening torque of the mounting screws must always be given for track systems. The tightening torque must also be given for screw connections that are subject to special requirements. The tightening torque must be cited next to the corresponding position number on the assembly drawing.

If a part (production parts, bought-in parts, standard parts) are used several times at different points within an assembly, this position should also be identified with its position number (several times) at the corresponding points on the assembly drawing. A screw connection can be presented as an example with a screw.

9.2.2 Electrical components

All electrical parts must also be marked with the thunderbolt symbol  in addition to the position.

9.2.3 Welded assemblies

A two-digit position number is to be used for individual welded parts.
Example:

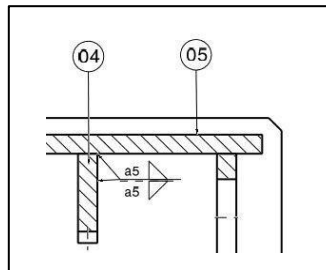

9.2.4 Lubrication points

Lubrication points are labeled using symbols from the CATIA standard catalog.

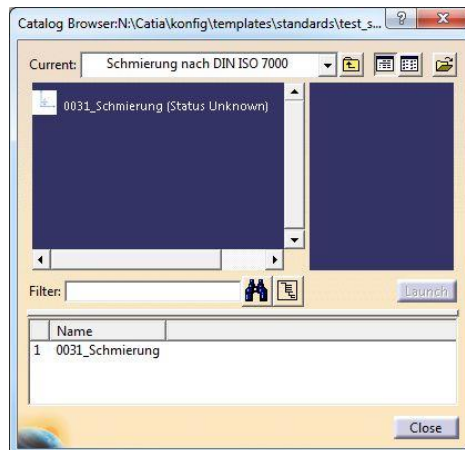
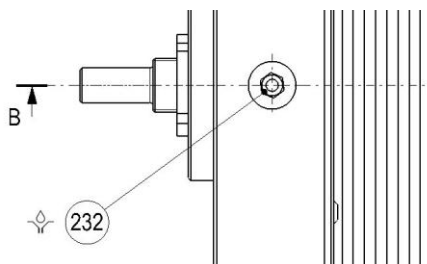

9.2.5 *Presentation of the pin holes in the drawings*

Essentially:

Pin holes have to be drilled to the finished dimension for positioning workpieces. The dimensions for the internal are labeled with the tolerance indicator +/- 0.02; the hole \emptyset is identified based on this example

Example: \emptyset xxH7

Exception:

The following process applies, if the pin hole is to be drilled for assembly. The pin hole is to be prefabricated according to the table for bore dimensions. Only the part to be screwed on is predrilled.

Table for predrilling dimensions:

Diameter range of drill holes	6 – 8 mm	10 – 16 mm
Undersize for predrilled hole	-1 mm	-2 mm

Example of exception:

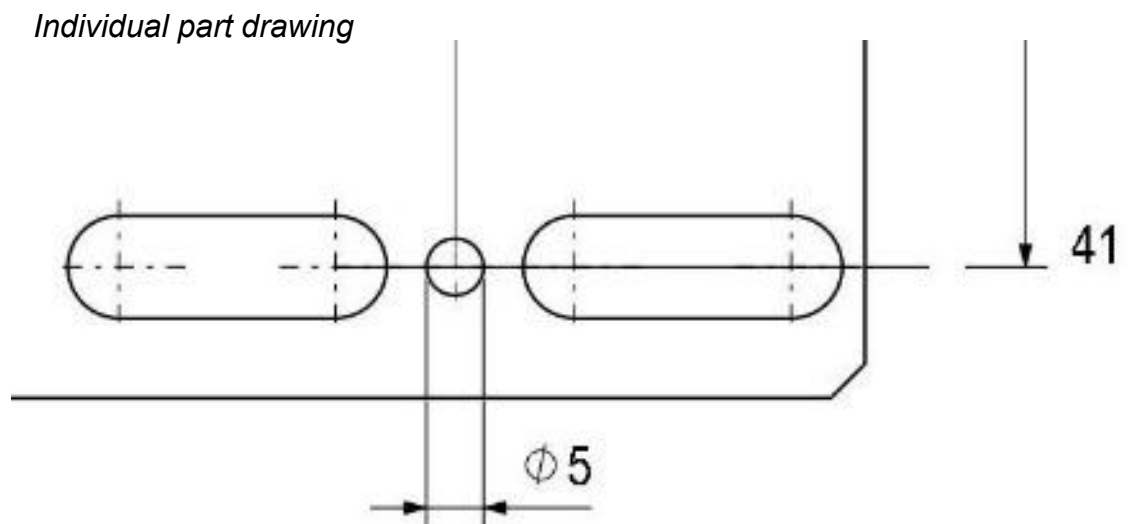

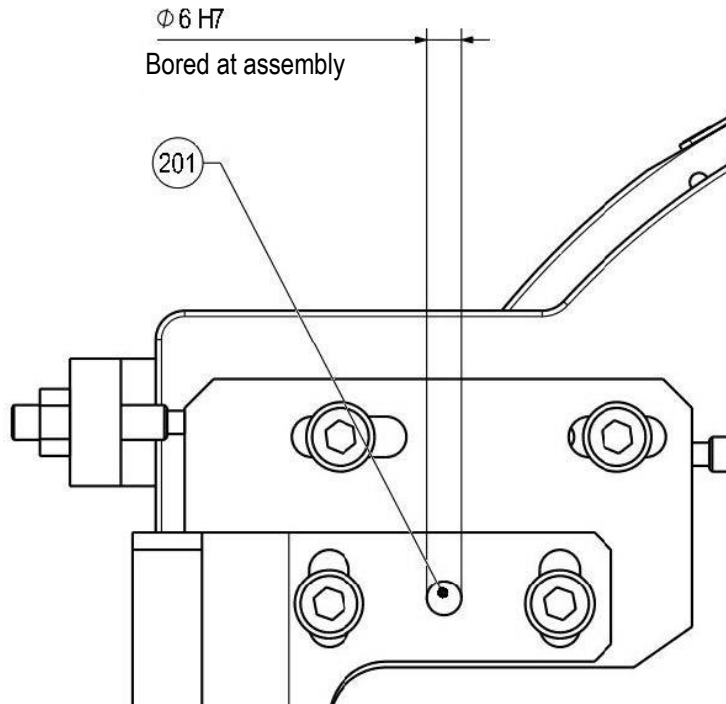

For workpieces that are also subject to a hardening process, the addition “bore hole soft” also has to be included in the description.

This would result in the following label for the example: $\phi 5$ soft drill hole.

9.3 General information (process in CAD)

The **CATIA Specification** (BN 10.030) has to be observed when creating drawings. Examples and references for their implementation can be found there.

9.4 Dimensioning

1. Dimensions in production drawings have to be associated with 3D when using CATIA and other 3D systems and may not be manipulated.
2. Generally valid text is inserted above the title block in the working view. Care should be taken that sufficient space is left for the translation beneath the inserted text, as translations are frequently longer.
3. Edited dimensions such as sheet thicknesses ($t=2\text{mm}$) through attached text is not permitted. A correspondingly dimensioned side view of the workpiece is required to do this.
4. Radii are to be sized in CATIA using their theoretic features. This point of intersection is to be provided with constraints congruent with the lines that form this intersection.
5. The reference elements (zero areas) should not change within a drawing. Preference should be given to edges and areas when selecting reference elements.
6. The details of form and position tolerances are performed in accordance with DIN ISO 1101.
7. The part list of bought-in and manufactured parts is recorded in AMS by Broetje Automation. Design offices agree the supply format for their part list with the project manager. Items can be supplied in Excel format, for example.
8. Ensat threaded nuts have to be assigned to the production part in which they are fitted.
9. The general tolerance to be used for dimensions without tolerance details must be given above the text block.

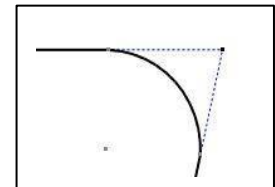

10. The interface quality has to be stipulated based on the following table.

Surface Details	
	Ra [μm]
Polished	0.02 – 0.2
Sanded	0.8
Fine Finished	1.6
Finished	3.2
Roughed	6.3 / 12.5
Manufactured without material separation	

11. The table drawing format for manufacturing documents may not be used.
12. Details, such as “*Part XY mirror image*” or similar, are **not permitted** on the production drawing for a mirror-image geometry.
13. Names and their translations have to correspond to parameters from the (standard/language tool) and have to be taken from the language database.
14. There is an isometric view for every workpiece (no smaller, to-scale representation possible).
15. Only the external dimensions have to be applied in drawings for laser and flame-cut parts, which are manufactured with the help of 3D data. External design offices must previously agree this procedure with the Broetje staff responsible.
16. Processing is not required for sheet bent components.
17. For simple parts there is the option of having these manufactured based on CAD data. In this case, sizing is sufficient in the form of dimensions (length, width, height) with details of the general tolerance (DIN ISO 2768). Any dimensions that differ from the general tolerance have to be included on the drawing.

9.5 Test dimensions

Dimensions that have to be documented have to be identified as a test dimension in the assembly/individual part drawing.

Test dimensions have to be sequentially numbered and the entire number entered above the title block. In parallel, the text for the *identification (drawing no./index)* and for the *identification SNR (date, seq. no.)* have to be placed above the title block.

Example:

Anzahl der Prüfmaße: 12
Quantity of inspection dimensions:

Kennzeichnung (Z-Nr./Index) mit passender Schriftgröße
Identification (drawing no./index) with suitable font size XXX.XXX.XXX / YY

Kennzeichnung SN Nr. (Datum, Lfd.Nr.) mit passender Schriftgröße
SN identification number (date, serial No.) with suitable font size JJMMTTxx

CI	Neuanlage	Kopf	10.02.2016	
Index/Index	Beschreibung/Description	Name/Name	Datum/Date	
	Bearb./Design Kropf	Dokumentenkategorie/Document class Fertigungszeichnung Manufacturing drawing	Baugruppen-Nr. Assy no.	
	Prüfer/Checked	Benennung/Title Abdeckplane Covering tarpaulin	Werkstoff/Material kein	
	BA-Intern BA-internal Bekarew_E		Dokumentenstatus/Document status in Arbeit	
	Ausgabedatum/Issue Date	Zusatz/Extension	Maßstab	Sprache

Alle Rechte gemäß ISO 10015 vorbehalten. Zeichnungsnummer/Index/Drawino no./Index

A comment should be left, if there are no test dimensions:

Anzahl der Prüfmaße: 0000
Quantity of inspection dimensions:

Kennzeichnung (Z-Nr./Index) mit passender Schriftgröße
Identification (drawing no./index) with suitable font size XXX.XXX.XXX / YY

CI	Neuanlage	Kopf	10.02.2016	
Index/Index	Beschreibung/Description	Name/Name	Datum/Date	
	Bearb./Design Kropf	Dokumentenkategorie/Document class Fertigungszeichnung Manufacturing drawing	Baugruppen-Nr. Assy no.	
	Prüfer/Checked	Benennung/Title Abdeckplane Covering tarpaulin	Werkstoff/Material kein	
	BA-Intern BA-internal Bekarew_E		Dokumentenstatus/Document status in Arbeit	
	Ausgabedatum/Issue Date	Zusatz/Extension	Maßstab	Sprache

Alle Rechte gemäß ISO 10015 vorbehalten. Zeichnungsnummer/Index/Drawino no./Index

Test Dimension Identification

A test dimension is identified and sequentially numbered as follows for lengths and angle dimensions.



The number is to be placed in brackets, followed by an empty space. **All** test dimensions are sequentially numbered starting with 1 and counted in ascending order.

A test dimension is identified as follows for form and positional tolerances.

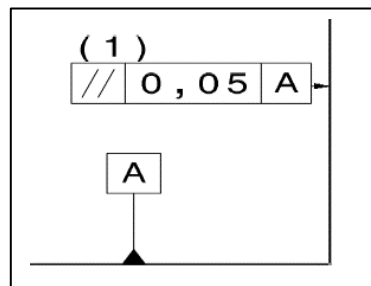

The labeling here therefore only relates to the numbering. The test dimensions are also sequentially numbered here. Length and angle dimensions and form and positional tolerances are jointly through numbered.

If the number of the test dimensions is > 0 , the following stamp/text must be added from the catalog (CATIA V5) above the text block.

Identification SN no. (date, sequential number) with appropriate font size

JJMMTTxx

For other CAD systems, this comment must be generated manually.

9.6 Engraving

The site of the etching is identified by the information XXX.XXX.XXX/YY and has to be selected in such a way that the etching is visible in the installation position and does not impair the function.

The drawing number (XXX.XXX.XXX) and index are specified (YY).

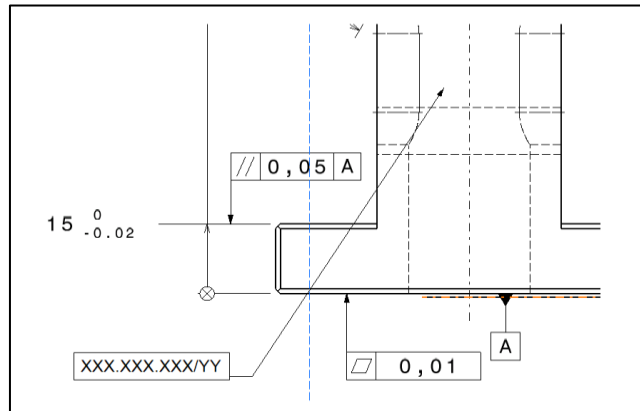

9.7 Weight

The weight has to be detailed above the title box on assembly drawings and the drawing of the welded assembly:

Weight: 27.5 kg

BRÖTJE AUTOMATION		Index	Bz
<small>Wiedergabe sowie Vervielfältigung dieses Dokuments, Verwertung und Mitteilung seines Inhalts sind verboten, soweit nicht ausdrücklich gestattet. Zuwiderhandlungen verpflichten zu Schadensersatz. Alle</small>			

9.8 Drawings of welded parts

Weld seams are labeled according to “BN10.050 Weld Instruction Design.”

For more information about weldments, please refer to the document “BN10.050 Welding Instruction Construction”.

Please take any further information about welded structures from the “schweißtechnische_anweisung_konstruktion.pdf” document (Weld Instruction Design).

9.9 Title block

Fields of the title block

01	Nissanlage		Kopf	28.08.2014
Index/Index	Beschreibung/Description		Name/Name	Datum/Date
	Bearb./Design Kropf	Dokumentkategorie/Document class Schweißzeichnung Welding drawing	Baugruppen-Nr./Assy no.	
	Prüfer/Checked Wilms,E	Benennung/Title Fahrwerk Carriage	Werkstoff/Material S 355J2+N (1.0577)	
	BA-intern/BA-internal Hoffmann,H	Zusatz/Extension SWT	Dokumentenstatus/Document status AMS Freigabe	
Ausgabedatum/Issue Date	Zeichnungsnummer/Index/Drawing no./Index		Maßstab Scale	Sprache Language
Alle Rechte gemäß ISO 16016 vorbehalten. All rights reserved in accordance with ISO 16016	257.094.101/01		1:1	Blatt Sheet
Ext. Skiz./Z-Nr./Ext. parts list./Drawing no.			de/en	1/1

01 / Editor
02 / Checker
03 / BA internal
05 / Index/description/name/date
11 / Document category
09 / Addition Name

04 / Proof of ownership
07 / External Part Lists no.
06 / Issue date
08 / Name
10 / Drawing number/index

12 / Assembly group number
13 / Material entry
14 / Document status
15 / Scale
16 / Language
17 / Page search / Page No.

The fields marked in red are mandatory fields. Fields marked in green are completed with the appropriate tools and have to be checked. A combination of these is possible.

The fields may not be edited, deleted, or recreated. The field name has to be left as it is.

Importance of the fields (**RED** = mandatory field):

1. **Editor**: editor of the drawing – when the drawing is created by an external office, the company identifier follows the editor after a forward slash.
2. **Checker**: the checker approves a drawing. Editor and checker may not be identical when a drawing is first approved.
3. **BA internal**: contact partner and person responsible for the drawing at BA
4. **Proof of ownership** according to ISO 16016. This entry is added on all drawings by an ownership stamp that includes a foreign language entry.
5. **Index**: drawings start with the Index 01. The author of the newly created drawing is generally the same as the editor of the drawing. The first issue date has to be taken from the first index.
6. **Issue date**: Date of approval of the drawing at ERP following a successful check.
7. **External part list numbers** if required.
8. **Name** is selected during generation from the language database.
9. **Addition** (name): if the name contains language-neutral content (such as X1, X2, 1.1, 1.2m welded part, size dimensions), this part has to be entered the field “Addition name.”
10. The current **index** of the drawing is added to the **drawing number** following a forward slash.
11. **Document category** is entered by the system.
12. **Assembly number** is entered when the customer documents are created. (project-dependent information)
13. **Material** must be detailed for single parts/assemblies that only consist of one material. This is carried out automatically when working with CATIA V5 and CIM DATABASE as material is allocated in 3D. Otherwise, the material has to be entered manually. “See part list” is entered for individual parts/assemblies that consist of different materials. Care should be taken that the same material is always assigned to 3D and the drawing, check repeatedly, if necessary.
14. **Document Status** is transferred from BA-PDM.
15. **Scale**: primary scale on the drawing.
16. **Language** is updated for customer documents.
17. **Page number**: total number and current page

Naming conventions (name/definition)

- If the name contains language-neutral content (such as X1, X2, 1.1, 1.2m welded part, size dimensions), this part has to be entered in the field “Addition Name”.
- Abbreviations (lef., rig., etc.) are not permitted here. The description “*Complete*” forms the only exception. This is abbreviated as follows:
- (Example: bracket, complete)
- Take care with spelling. Umlauts are permitted in drawing/text block. (Umlauts and empty spaces are not permitted for file names.)
- The abbreviation SWT has to be entered in the “Addition Name” field for welded parts.

If there is further language-neutral name content in the “*Addition Name*”, then the abbreviation SWT has to be entered as follows in the “*Addition Name*” field: **X1 - SWT**

Index Entry

Changes in the drawings and designs are clear for approving the manufacturing documents and have to be documented without restriction. For CATIA V5 drawings that have to be administered in BA-PDM, the change has to be documented in BA-PDM. BA-PDM enters the change on the drawing.

Change Documentation Includes:

Change index = 01, 02, 03 ...

Change description = clear description of the change made

(Always refer, if possible, to the previous condition/value, e.g. from ... to ..., previous ... after)

Name = Name of the designer

Date = Date of the change

In addition, the corresponding change index **must** be positioned within the immediate vicinity of any changes made.

However, all change indices are entered on a multiple-page drawing, although only the last three are displayed.

Note: A maximum of the last 6 indices is displayed for CATIA V5 drawings that are managed on each page of the drawing.

9.10 Drill hole tables

No form of drill hole tables is permitted.

10 Data transmission

- 1) Documents are dispatched by FTP (access required).

Further information about this can be requested from the IT department on
Tel. +49-4402-966443.