



**BROETJE-AUTOMATION FRANCE
SUPPLIER DOCUMENTATION MANAGEMENT**

-Written by : Harold Mouafo Tatang (Quality Assurance)

-Released by : Arnaud FERRE (QHSE Manager)

Unit: BA France
Name: BAFR_Q_IN_Supplier documentation
Process owner: Quality
Status: 10/01/2025

Content

I	<u>Documentation of components</u>
II	<u>Provision of documentation</u>
III	<u>Deliverables set</u>
IV	<u>Design set</u>
V	<u>Manufacturing set</u>
VI	<u>Custom requirements</u>
VII	<u>Storage documentation structure</u>
VIII	<u>Deliverables naming</u>
IX	<u>Additional information</u>

Click on this icon anywhere
in the document to
comeback to this page

Content

I Documentation of components

Legal basis

In order to ensure the safety of products, state laws and regulations of private organizations oblige manufacturers and installers of technical products to provide "technical documentation".

In the EU, relevant [EC directives](#) such as the [Machinery Directive](#), the [ATEX Directive](#), the [Low Voltage Directive](#), the [Pressure Equipment Directive](#) or the Product Safety Directive, which have been transposed into national law by the member states must be mentioned.

Similarly, for deliveries to the United States, [US regulations](#) such as [OSHA\(Occupational Safety and Health Administration\)](#) , [NEC\(National Electrical Code\)](#), [UL \(Underwriters Laboratories\) Standards](#) are just as important for the same reasons.

Due to these requirements, it is essential that Broetje-Automation and its suppliers ensure complete documentation.

II Provision of documentation

Requirements

According to Broetje requirement, the documentation is to be delivered in digital format

Partial deliveries

In the case of partial deliveries, the uniqueness of delivered components in the documentation supplied must be maintained.

- *Documents to be produced per drawing must be sent with the respective part at the time of delivery.*
- *Cross-sectional documents must also be adapted to the deliveries. Example: certificate of compliance:*
 - For each partial delivery, a certificate of compliance with the order must be enclosed with the individual order items delivered.

III Deliverables set

Depending on purchase order requested, the documentation set and deliverables can change:

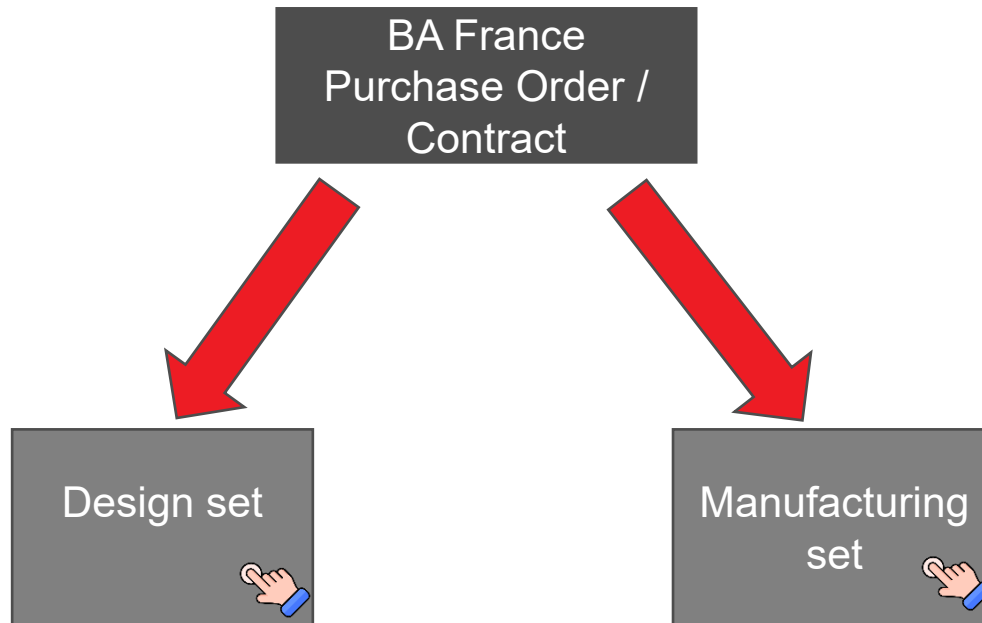

This icon means that you can get directly to the part, by **clicking** on it

IV Design set

List of deliverables (depending on product complexity and regulations) :

2D Drawings

3D files

Bill of Material (BOM)

Operator manual

Maintenance manual

Spare part List

One Pager document as a short maintenance manual

Training Manual

Risk assesement

Electric documents

Pneumatics documents

Hydraulic documents

 Template provided by BA

 Template provided by Supplier

V Manufacturing set

List of deliverables (depending on product complexity and regulations) :

CoC (Certificate of Conformity)

Welding process & certificates

Welding visual inspection

Quality Inspection Plan (QIP)

Acceptance protocol (AP)

Calibration of certificates (ISO 17025)

Load test report

Electrical test report (ISO 60204)

Hydraulic / Pneumatic Leakage report

Hydraulic / Pneumatic pressure test report

Surface treatment certificate

Paint control report

Photos

Template provided by BA

Template provided by Supplier

Content

V Manufacturing set

Template Certificate of conformity (CoC) (1/2)

Order no. Broetje-Automation

- NOTE :**
- 1 CoC per item
 - Pdf version requested

Certificate of Conformity acc. DIN EN 10204-2.1

General part									
Customer	BA France S.A.S Member of Broetje-Automation GmbH 41 bis avenue Jean Monnet 31770 Colomiers, France			Company / Supplier			XXXXXX		
Order no.	XXXXXXX			Delivery note no.			XXXXXX		
				Order date			XXXXXX		
Order scope Bestellumfang									
Item	Mat. Nbr.	Eq. Nbr.	Manufacturer S/N (if applicable)	P/N (GSE)	HTZ	Designation	Qty	Comments	
1									
2									

Supplier name and adress

Delivery note no.

Order date

Possible comments can be included here.

Informations about the item (see drawing & Purchase Order)

Ordered quantity per item

V Manufacturing set

Template Certificate of conformity (CoC) (2/2)

Statement	
This is to certify that the prespecified product has been tested and complies with the order/ specification/ manufacturing documents.	
Date , Name & signature	

Date, name and signature of the creator of document are necessary



V Manufacturing set

QIP (Part control checklist) (1/2)

NOTE :

- 1 checklist per purchase order
- Pdf version requested

It is a structured document outlining the procedures, criteria, and frequency of inspections to ensure that products or processes meet predetermined quality standards. It typically includes inspection checkpoints, acceptance criteria, sampling methods, and responsibilities of personnel involved in the inspection process.

General information about the purchase and the supplier / manufacturer

Quality Inspection Plan (QIP)		Tool Reference Photo					
= Populated By Supplier / Rempli par fournisseur		 QIP GENERATED:					
CONTROL CHECKLIST:							
Project 37932 - Work Package 4 Small Jigs & Tools							
Supplier		Tool Designation:					
FAL2 Item #		Quantity to control:					
Daughter Project:		Product Complexity:					
Work Package:		HTZ:					
Name of Examiner:		MAT:					
Date (MMDDYYR):		EQ #'s:					
Control criterias <i>Critères de contrôle</i>	To be controlled A Contrôler	Controlled by Contrôlé par	Date	Conform Conforme	Non-conform Non-conforme	Non applicable	Comments / Specification Commentaires / Spécification
QUANTITATIVE CONTROL CONTRÔLE QUANTITATIF							
Tool quantity Quantité outillage	X	0	00-Jan-00				
Sub-assembly quantity Quantité de sous-ensembles	X	0	00-Jan-00				
Other checks defined by BAFR Autres critères à définir par BAFR		0	00-Jan-00			X	
VISUAL CONTROL : FINAL ASPECT CONTRÔLE VISUEL : ASPECT OUTILLAGÉ / FINITION							
General aspect (scratches, bumps) Aspect général (rayures, choocs)	X	0	00-Jan-00				
Painting aspect Peinture : Couleur, aspect, couleurs		0	00-Jan-00			X	
No angles & sharp edges Pas d'angles et d'arêtes vives	X	0	00-Jan-00				
Labelling Marquage	X	0	00-Jan-00				

Those blues box are the answer or comments of the Supplier, and grey box are non applicable criterias depending on the item

Control criteria's: those with a cross in a green box are the ones that will be check by the supplier /manufacturing

Content

V Manufacturing set

QIP (part control checklist) (2/2)

NOTE :

- 1 checklist per purchase order
- Pdf version requested

Hydraulic Test Report Rapport d'essai hydraulique	X	0	00-Jan-00				
Pneumatic Pressure Test Report Rapport de test de pression pneumatique		0	00-Jan-00			X	
Electric Test Report (ISO 60204) Rapport d'essai électrique (ISO 60204)		0	00-Jan-00			X	
Sealing Report Rapport d'étanchéité		0	00-Jan-00			X	
Maintenance Manual Manuel de maintenance	X	0	00-Jan-00				
CE Certificate Certificat CE		0	00-Jan-00			X	
Delivery note Bon de livraison	X	0	00-Jan-00				
Other Documentation defined by BAFR Autre documentation définie par BAFR		0	00-Jan-00			X	
CUSTOMS DOCUMENTATION : REPORTS & CERTIFICATES (MUST BE PROVIDED IN ENGLISH) DOCUMENTS DOUANIERS : CERTIFICATS ET RAPPORTS (DOIT ÊTRE FOURNI EN ANGLAIS)							
Customs documents (TSCA title VI) wood Documents douanes (TSCA title VI) wood		0	00-Jan-00			X	
LACEY act (organic matter) LACEY act (matière organique)		0	00-Jan-00			X	
Export US electronic product certificate FORM FDA 2877 Certificat d'exportation de produits électroniques américains FORMULAIRE FDA 2877		0	00-Jan-00			X	
FINAL RESULT Resultant Final							
Signature of BAFR Quality Signature:				Signature of Examiner: Signature:			

Every QIP must be signed by BA France Quality team before to release the product

Every QIP must be signed by supplier examiner before to send to BA France

V Manufacturing set

QIP (Part Measurement report)

- NOTE :**
- 1 measurement report per Equipment N°
 - Values defined on Control plan (One control plan named « xxxxx-ctrl » with bubbles provide with every order)
 - Pdf version requested

Q - Dimensional Control Report									
Q - PV de contrôle dimensionnel									
Informations générales									
Supplier / Manufacturer: Fournisseur / Fabricant :			Component Designation: Désignation repère						
Order no.: Commande N°:			Measurement Complexity Group 111 < 50% 1121 - 20 50% 1121 - 50 90%						
BAFR Project: N° affaire BAFR:			37932			HTZ:			
Daughter Project N° affaire fille BAFR:						MAT #			
						EQ #			
Result							Evaluation		
Résultat							Bilan		
PM	Measurement device:	device Ident. No.:	Set Value	Tolerance	Measured Value	Deviation	o.k	n.o.k	Remarks
	(See legend below)			Tolérance	Valeur mesurée (mm)	Ecart	OK	KO	Remarques
PM	Moyen de mesure	N°Id du moyen de mesure:	Côte (mm)	(+/-)	Valeur mesurée (mm)	Ecart	OK	KO	Remarques
1									
2									
3									
4									
5									
6									
7									
8									
9									
10									
11									
12									
13									
14									
Examineur									
Name of Examiner: Nom de l'examineur:					Date of Control: Date du contrôle:				
Signature of Examiner: Signature:					Location of Examination: Emplacement du contrôle:				

General information

Measurement device information

Results and evaluation

Examiner / signature / location

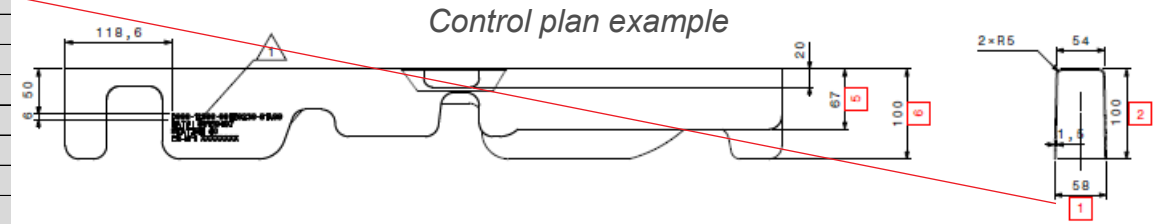

Content

V Manufacturing set

QIP (Part calibration LOG)

NOTE :

- 1 Calibration LOG per item
- Pdf version requested

MEASUREMENT DEVICES USED		
Item	Serial #	Date of Last Calibration

Item Number

Date of last calibration of the measurement tool according to the ISO 17025

Identification number of the tool that has been use for the control

V Manufacturing set

Paint Protocol (1/2)

Q – Paint thickness protocol
Q – Protocole de relevé d'épaisseur de peinture

Stand : 12.06.2024

1. Test object

BA France Project no.	
PO / Contract No	
Manufacturer name	
Tool equipment No	
Applicable standards	<ul style="list-style-type: none"> • BN30.050-Coating (Link) • Indicate other standards applicable

Fill this part with the information about the product

2. Product description

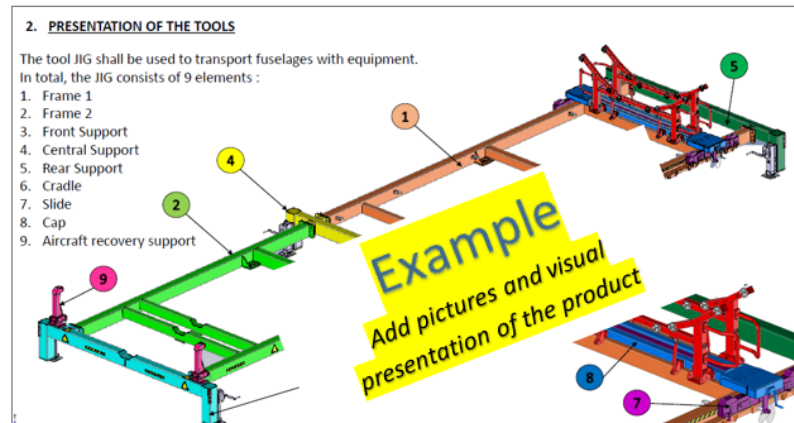

Picture of the tool and the parts that have to be controlled – **Must be completed by BA France**

V Manufacturing set

Paint Protocol (2/2)

NOTE :

- 1 Paint report per Equipment N°
- Pdf version requested

Q – Paint thickness protocol
Q – Protocole de relevé d'épaisseur de peinture



Stand : 12.06.2024

3. Measurement results

Number of parts N°, measurement points, applicable thickness need to be defined before to send to the supplier.

Part N°xxxx	Measurement point	Applicable minimum thickness (µm)	Measured value (µm)	Ok / NoK
	First	Min. xxx µm		
	Second	Min. xxx µm		
	Third	Min. xxx µm		
	Fourth	Min. xxx µm		
	Fifth	Min. xxx µm		

Part N°xxxx	Measurement point	Applicable minimum thickness (µm)	Measured value (µm)	Ok / NoK
	First	Min. xxx µm		
	Second	Min. xxx µm		
	Third	Min. xxx µm		
	Fourth	Min. xxx µm		
	Fifth	Min. xxx µm		

Part N°xxxx	Measurement point	Applicable minimum thickness (µm)	Measured value (µm)	Ok / NoK
	First	Min. xxx µm		
	Second	Min. xxx µm		
	Third	Min. xxx µm		
	Fourth	Min. xxx µm		
	Fifth	Min. xxx µm		

Put here results of the measurement of the parts listed in the description above

Measurement device identification N°	
Last calibration date	
Next calibration date	
Quality inspector	
Date & Signature	

Date and sign the document with the name of the examiner, as well as the measurement device identification and calibration dates

VI Custom requirements

ISPM 15 certification (for every wood component or box)

TSCA title VI for every plywood component

LACEY act for organic material

ECCN (Export Control Classification Number) per item delivered

VII Storage documentation structure

1. Specific head folder naming must be respected to avoid any misunderstanding, see below :

«Supplier_name_Purchase_Order (PO)_N°_item_N°» → Example « Hydro_System_PO_79275_Item_2022 »

2. Name of the folder where documents will be stored should be done following a specific structure, see below:

- 01_Material_certificates
- 02_Inspection&Testing
- 03_Treatment_certificates (NDT, Surface finishind,...)
- 04_Manufacturing_Documents
- 05_Others

Examples :

- QIP & Measurement reports → Folder 02
- Calibration certificates → Folder 02
- Tests (electrical / load / pressure...) → Folder 02
- Paint protocol → Folder 03
- Welding process and certificates → Folder 04
- Commercial parts / standards → Folder 05

NOTE : An Excel summary with all parts / raw material names can be requested by Broetje during manufacturing phasis

3. Document transfer (when everything is stored, all documents are signed, well named, transfer via FTS platform, One drive, etc.)

VIII Deliverables naming

Type of deliverable	Naming of the document
Raw material (CCPU)	PO-N°_ItemN°_PosN°_Material type → (<i>Plate, tube, bar</i>)
CoC (Certificate of Conformity)	PO-N°_ItemN°_EqN°_CoC
Welding certificates	PO-N°_ItemN°_Certif type_Personnel Qualif
Welding visual inspection	PO-N°_ItemN°_PosN°_EqN°_VT report
QIP (Checklist part)	PO-N°_ItemN°_EqN°_QIP
QIP (Measurement report)	PO-N°_ItemN°_EqN°_Dim report
Acceptance protocol (AP)	PO-N°_ItemN°_EqN°_AP
Load test report	PO-N°_ItemN°_EqN°_Load_test
Electrical test report (ISO 60204)	PO-N°_ItemN°_EqN°_Electrical_test
Hydraulic / Pneumatic Leakage report	PO-N°_ItemN°_EqN°_Leakage_test
Hydraulic / Pneumatic pressure test report	PO-N°_ItemN°_EqN°_pressure_test
Surface treatment certificate	PO-N°_ItemN°_PosN°_treatment certificate
Paint control report	PO-N°_ItemN°_EqN°_Paint thickness report
Commercial / standard parts	PO-N°_ItemN°_PosN°_standard part

VIII Deliverables naming

Example: Measurement report for Equipment number 285123 of the item 685 (PO-N°. 87534)

- PO-N°. : 87534
- Item N°: 0685
- Eq N° : 285123
- Document: Dimensional report

➤ **File name** → **87534_0685_285123_Dim report.pdf**

IX Additional information

Broetje-Automation will of course support in case of need for clarification. Please contact:

- Harold MOUAFO TATANG (Quality Assurance project FAL US J&T) : *harold.mouafo-tatang.external@broetje-automation.fr*
- Dorian CALAS (Quality Assurance project FAL US Trailers) : *dorian.calas@broetje-automation.fr*
- Arnaud FERRE (QHSE manager): *arnaud.ferre@broetje-automation.fr*

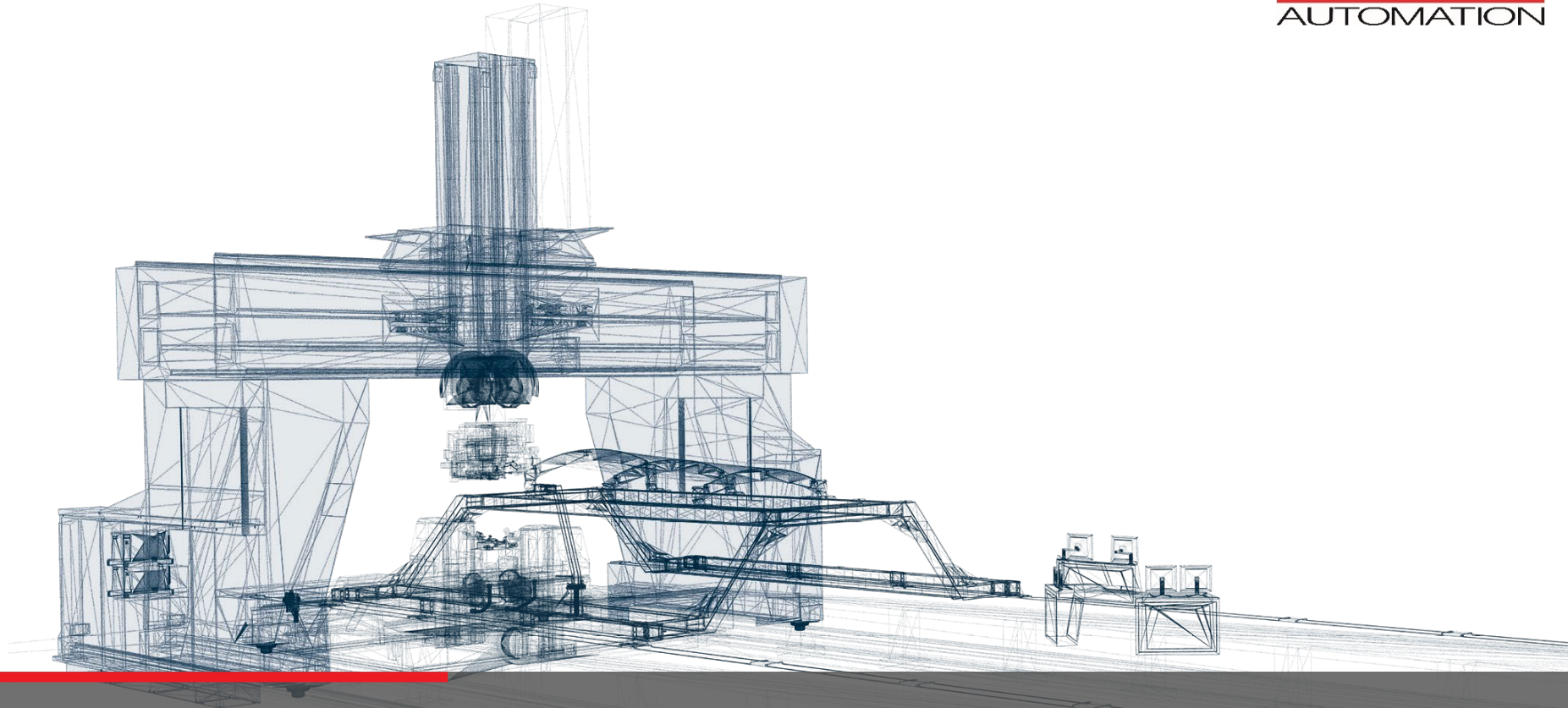

Thank you!